

## Gleim Sport Pilot Syllabus

Third Edition, Second Printing

Updates

March 2019

NOTE: Text that should be deleted is displayed with a line through it. New text is shown with a blue background.

If you are tested on any content not represented in our materials or this update, please share this information with Gleim so we can continue to provide the most complete test preparation experience possible. You can submit feedback at [www.GleimAviation.com/questions](http://www.GleimAviation.com/questions). Thank you in advance for your help!

The changes in this update reflect current FAA literature and procedures as well as updated editions of Gleim materials used for reference throughout the syllabus.

### Introduction

Page 2, Requirements for Sport Pilot Certificate, Item 1.e.1)i):

- i) Your certificated flight instructor (CFI) or fixed-base operator (FBO) will be able to recommend an AME.
  - An FBO is an airport business that gives flight lessons, sells aviation fuel, repairs airplanes, etc.
  - Also, the FAA publishes a directory that lists all authorized AMEs by name and address. ~~Copies of this directory are kept at most FAA offices, ATC facilities, and Flight Service Stations (FSS). Alternatively, go to the Gleim website at [www.gleim.com/aviation/amesearch.php](http://www.gleim.com/aviation/amesearch.php).~~ **found online at [www.faa.gov/pilots/amelocator](http://www.faa.gov/pilots/amelocator).**

Page 3, Requirements for Sport Pilot Certificate, Items 2.c. and 3.: This section was previously edited in a July 2016 update.

- c. Contact the **a** CFI, ACR, ASI, or DPE and **to** schedule an appointment to ~~obtain a student pilot certificate for sport pilot training. Bring the following documents and records to the appointment:~~ **have your** 1) ~~A completed and signed FAA Form 8710-1, *Airman Certificate and/or Rating Application*, (or FAA Form 8710-11 for Sport Pilot only) via Integrated Airman Certification and Rating Application (IACRA), the web-based certification/rating application portal;~~ **processed and submitted to the FAA's Airman Certification Branch.** ~~The web address is <https://iacra.faa.gov/>. Applicants also have the option to apply for a student pilot certificate in paper format on the FAA Form 8710-1 (or FAA Form 8710-11 for Sport Pilot only).~~
  - 1) **Make sure to bring the following documents to your appointment:**
    - a) **Your completed and signed application**
    - 2) **b) An acceptable form of photo identification:**
    - 3) **c) Documents necessary to verify citizenship, such as a U.S. birth certificate or U.S. passport:**

3. Pass your FAA pilot knowledge test, which consists of 40 multiple-choice questions and is administered at an FAA-designated computer testing center. You will attend one of hundreds of computer testing centers after you have prepared for your test. Everything you need to prepare for your FAA pilot knowledge test is in your Gleim **Sport Pilot FAA Knowledge Test** and **Pilot Handbook** books. The Gleim **FAA Test Prep Online** will facilitate your study. (To find out exactly what to expect from the computer testing center of your choice, use FAA Test Prep’s convenient vendor emulation testing format.) Use the Gleim **Online Ground School** for convenient, complete knowledge test study from any computer with Internet access.
  - a. We have estimated ~~28.5~~ 29.5 hours for complete preparation to completely prepare for your sport pilot knowledge test. You may turn to page 5 for instructions on how to begin at any time. See “Sport Pilot Syllabus Lesson Sequence and Times” beginning on page 7.
  - b. The further you study for your FAA sport pilot airman knowledge test before you commence your flight lessons, the better!

Page 4, How to Proceed, Item 5.a.:

- a. You may want to search our CFI Directory on our website at [www.gleim.com/aviation/cfi/search/](http://www.gleim.com/aviation/cfi/search/) [www.GleimAviation.com/findacfi](http://www.GleimAviation.com/findacfi).

### Sport Pilot Ground Training Syllabus – Airplane

NOTE: For all ground lessons, the page numbers and numbers of questions were removed from the Text References.

Page 14, Ground Lesson 2: Airspace, Text References:

<i>Pilot Handbook</i> Study Unit 3 Contents		<i>Sport Pilot FAA Knowledge Test Prep</i> Study Unit 2 Contents	
3.9	Radio Communications and Phraseology	2.1	Airspace Overview
3.10	Airports without an Operating Control Tower	2.2	Class D Airspace
3.11	Automated Weather Reporting Systems	2.3	Class C Airspace
3.12	Airports with an Operating Control Tower	2.4	Transponder Codes
3.13	Automatic Terminal Information Service (ATIS)	2.5	Radio Phraseology
3.18	Emergencies	2.6	ATC Traffic Advisories
3.19	Radio Failure Procedures	2.7	ATC Light Signals
3.20	Emergency Locator Transmitter (ELT)	2.8	Emergency Locator Transmitters (ELTs)
3.22	Transponder Operation		
3.24	General Dimensions of Airspace		
3.25	Controlled and Uncontrolled Airspace		
3.27	Class B Airspace		
3.28	Class C Airspace		
3.29	Class D Airspace		
3.30	Class E Airspace		
3.31	Class G Airspace		
3.32	Special-Use Airspace		
3.33	Other Airspace Areas		
3.34	Special Flight Rules Areas		
3.35	Next Generation Air Transportation System (NextGen)		

Page 15, Ground Lesson 3: Federal Aviation Regulations -- 14 CFR Parts 1 through 71, Text References:

<i>Pilot Handbook</i> Study Unit 4 Contents	
4.1	Federal Aviation Regulations
4.2	Part 1 – Definitions and Abbreviations
4.3	Part 21 – Certification Procedures for Products and <b>Parts Articles</b>
4.4	Part 39 – Airworthiness Directives
4.5	Part 43 – Maintenance, Preventive Maintenance, Rebuilding, and Alteration
4.6	Part 61 – Certification: Pilots, Flight Instructors, and Ground Instructors

Page 19, Ground Lesson 6: Aeromedical Factors and Aeronautical Decision Making (ADM), Text References:

<i>Pilot Handbook</i> Study Unit 6 Contents	
6.1	Fitness for Flight
6.2	Hypoxia
6.3	Dehydration
6.4	Hyperventilation
6.5	Carbon Monoxide Poisoning
6.6	Decompression Sickness after Scuba Diving
6.7	Motion Sickness
6.8	Sinus and Ear Block
6.9	Spatial Disorientation
6.10	Illusions in Flight
6.11	Vision
6.12	Aeronautical Decision Making (ADM)
6.13	Weather-Related Decision Making
6.14	Stress and Flying
6.15	Identifying the Enemy
6.16	Single-Pilot Resource Management (SRM)
<b>6.17</b>	<b>Automation Management</b>

## Page 21, Ground Lesson 8: Weather Services, Text References:

<i>Pilot Handbook</i> Study Unit 8 Contents	<i>Sport Pilot FAA Knowledge Test Prep</i> Study Unit 8 Contents
8.1 Flight Service Station (FSS)	8.1 Weather Briefings
8.2 Aviation Routine Weather Report (METAR)	8.2 Aviation Routine Weather Report (METAR)
8.3 Pilot Weather Report (PIREP)	8.3 SIGMETs and AIRMETS
8.4 Terminal Aerodrome Forecast (TAF)	8.4 Pilot Weather Report (PIREP)
<del>8.5 Aviation Area Forecast (FA)</del>	<del>8.5 Aviation Area Forecast</del>
8.6 Graphical Forecasts for Aviation (GFA)	8.6 5 Terminal Aerodrome Forecast (TAF)
8.6 7 In-Flight Aviation Weather Advisories	<del>8.7 Weather Depiction Charts</del>
8.7 8 Winds and Temperatures Aloft Forecast (FB)	<del>8.8 Radar Weather Reports</del>
8.8 9 Surface Analysis Chart	8.9 6 Significant Weather Prognostic Charts
8.9 10 Weather Depiction Chart Ceiling and Visibility Analysis (CVA)	8.7 In-Flight Weather
8.10 11 Radar Summary Chart Observations	8.11 8 Wind and Temperature Aloft Forecasts (FB)
8.11 12 Short-Range Surface Prognostic (PROG) Chart	
8.12 13 Low-Level Significant Weather (SIGWX) Chart	
8.13 14 DUATS Leidos Flight Service Online	
8.14 15 Aviation Weather Resources on the Internet	

## Page 23, Ground Lesson 10: Navigation and Preflight Preparation, Text References:

<i>Pilot Handbook</i> Study Unit 9 Contents	<i>Sport Pilot FAA Knowledge Test Prep</i> Study Unit 10 Contents
9.4 FAA Advisory Circulars (ACs)	10.1 Density Altitude
9.5 <i>Aeronautical Information Manual (AIM)</i>	10.2 Preflight Preparation
9.6 <i>Airport/Facility Directory (A/FD)</i> Chart Supplement U.S.	10.3 Weight and Balance
9.7 Notice to Airmen (NOTAM) System	10.4 Navigation
9.8 Flight Computers	10.5 Global Positioning System (GPS) Navigation
9.9 The Gleim Flight Computer	10.6 Determining Wind Direction and Speed
9.10 The Calculator Side of the Flight Computer	10.7 VFR Flight Plan
9.11 Conversion of Nautical Miles to Statute Miles and Vice Versa	10.8 Preflight Inspection
9.12 Speed, Distance, and Time Computations	10.9 FAA Advisory Circulars
9.13 Fuel Computations	10.10 <i>Airport/Facility Directory</i> Chart Supplements
9.14 True Airspeed and Density Altitude	
9.15 Corrected (Approximately True) Altitude	
9.16 Off-Course Correction	
9.17 Radius of Action	
9.18 Other Conversions	
9.19 Temperature Conversions	
9.20 The Wind Side of the Gleim Flight Computer	
9.21 Determining Magnetic Heading and Groundspeed	
9.22 Determining Wind Direction and Speed	
9.23 Determining Altitude for Most Favorable Winds	
9.24 Alternative: E6B Computer Approach to Magnetic Heading	
9.25 Information Side of Sliding Card (Gleim E6B)	
9.26 Electronic Flight Computers	
<del>9.27 ASA CX-2</del>	
<del>9.28 Sporty's E6B</del>	
<i>Pilot Handbook</i> Study Unit 11 Contents	
11.1 Preflight Preparation	
11.2 VFR Flight Plan	
11.3 Weight and Balance	
11.4 Navigation	
11.5 Diversion to an Alternate Airport	
11.6 Lost Procedures	

## Page 25, Ground Lesson 11: Airplanes and Aerodynamics, Text References:

<i>Pilot Handbook</i> Study Unit 1 Contents	
1.1	Definitions
1.2	The Airplane
1.3	Composite Construction
1.3.4	Axes of Rotation
1.4.5	Flight Controls and Control Surfaces
1.5.6	Forces Acting on the Airplane in Flight
1.6.7	Dynamics of the Airplane in Flight
1.7.8	Ground Effect
1.8.9	How Airplanes Turn
1.9.10	Torque (Left-Turning Tendency)
1.40.11	Airplane Stability
1.44.12	Loads and Load Factors
1.42.13	Stalls and Spins
1.14	Angle of Attack Indicators

## Page 26, Ground Lesson 12: Airplane Instruments, Text References:

<i>Pilot Handbook</i> Study Unit 2 Contents	
2.1	Pitot-Static System
2.2	Altimeter
2.3	Vertical Speed Indicator
2.4	Airspeed Indicator
2.5	Gyroscopic Flight Instruments
2.6	Turn Coordinator
2.7	Turn-and-Slip Indicator
2.8	Attitude Indicator
2.9	Heading Indicator
2.10	Magnetic Compass
2.11	Compass Errors
2.12	Glass Cockpit Instrumentation

## Page 27, Ground Lesson 13: Airplane Engines and Systems, Text References:

<i>Pilot Handbook</i> Study Unit 2 Contents	<i>Sport Pilot FAA Knowledge Test Prep</i> Study Unit 13 Contents
<del>2.12</del> Glass Cockpit Instrumentation	13.1 Electrical Systems
2.13 Airplane Engines	13.2 Lubrication System
2.14 How an Engine Operates	13.3 Engine Temperature
2.15 Ignition System	13.4 Engine Ignition Systems
2.16 Induction System	13.5 Carburetor Icing
2.17 Fuel System	13.6 Carburetor Heat
2.18 Oil System	13.7 Fuel/Air Mixture
2.19 Cooling System	13.8 Abnormal Combustion
2.20 Propellers	13.9 Aviation Fuel Practices
2.21 Full Authority Digital Engine Control (FADEC)	13.10 Miscellaneous Airspeed Questions
2.22 Electrical System	13.11 Taxiing Technique
2.23 Landing Gear System	13.12 Starting the Engine
2.24 Environmental System	13.13 Cold Weather – Attention
2.25 Deice and Anti-Ice Systems	

Page 28, Ground Lesson 14: Airplane Performance and Weight and Balance, Text References:

<i>Pilot Handbook</i> Study Unit 5 Contents	<i>Sport Pilot FAA Knowledge Test Prep</i> Study Unit 14 Contents
5.1 Determinants of Airplane Performance	14.1 Density Altitude Computations
5.2 Standard Atmosphere	14.2 Takeoff Distance
5.3 Pressure Altitude	14.3 Climb Performance and Thrust
5.4 Density Altitude	14.4 Range and Endurance
5.5 Takeoff Performance	14.5 Cruise Power Settings
5.6 Climb Performance	14.6 Crosswind Components
5.7 Cruise and Range Performance	14.7 Glides and Glide Speed
5.8 Glide Performance	14.8 Landing Distance
5.9 Crosswind Performance	14.9 Weight and Balance Definitions
5.10 Landing Performance	14.10 Center of Gravity Graphs
5.11 Stall Speed Performance	14.11 Center of Gravity Tables
5.12 Weight and Balance Overview	14.12 Landings
5.13 Weight and Balance Management	
5.14 Weight and Balance Terms	
5.15 Basic Principles of Weight and Balance	
5.16 Methods of Determining Weight and Balance	
5.17 Center of Gravity Calculations	
5.18 Center of Gravity Charts	
5.19 Center of Gravity Tables	
5.20 Weight Change and Weight Shift Computations	

**Sport Pilot Flight Training Syllabus – Airplane**

Page 32: Remove the lesson list and reading assignment table.

Page 33, Text References and Content:

**Text References:** This **For lessons with new learning items, this** section tells you which reference books you will need to study or refer to while mastering the tasks within the lesson. Abbreviations are given to facilitate the cross-referencing process.

**Content:** Each lesson contains a list of the tasks required to be completed before moving to the next lesson. A task may be listed as a “review item” (a task that was covered in a previous lesson) or as a “new item” (a task that is introduced to you for the first time). Each task is preceded by three blank “check-off” boxes, which may be used by your instructor to keep track of your progress and to indicate that each task was completed.

There are three boxes because it may take more than one flight to complete the lesson. Your instructor may mark the box(es) next to each task in one of the following methods (or any other method desired):

✓ - task completed to lesson completion standards	D - demonstrated by instructor * A - accomplished by you S - safe/satisfactory P - meets <b>or exceeds</b> PTS standards	1 - above lesson standard 2 - meets lesson standard 3 - below lesson standard
---	---	---

~~Most tasks are followed by book and page references that tell you where to find the information you need to study to accomplish the task successfully.~~

[ . . . ]

~~\*System suggested by the U.S. Air Force flying clubs~~

## Page 34, Reading Assignments for Flight Lessons:

You are expected to be prepared for each flight lesson. Our reading assignments will include text references for new tasks to help you understand what is going to happen and how and why you need to do everything BEFORE you go to the airport.

Each flight lesson in this book contains

- Objective
- Text references
- Content
  - ✓ Review items
  - ✓ New items
- Completion standards
- Comments, assignment, and notes

Next to each new item in the Content section, we have provided the page number(s) study unit-level references to read in *Sport Pilot Flight Maneuvers and Practical Test Prep* (FM) and/or *Pilot Handbook* (PH); and the section to read, if appropriate, in your airplane's Pilot's Operating Handbook (POH).

For the new items, you should read the material and attempt to understand the basic concepts. Try to anticipate and visualize the concepts and flight maneuvers. With this basic knowledge, your instructor can expand on the specific and finer points, especially when explaining how a task is done in your specific airplane.

After your flight lesson, task items are fresh in your mind; they will make sense, and you should be able to understand and learn more.

Study review items so you can explain them to your instructor and your examiner.

After you study, relax and plan a time to begin reading to prepare for the next flight lesson.

**NOTE:** *Sport Pilot Flight Maneuvers and Practical Test Prep* contains two parts; study units in Part I are numbered 1-6, and study units in Part II are numbered I-X. You can make use of the comprehensive index in the Gleim books if you need to analyze specific task element-level details.

### Study Tips

- As you read the material, attempt to understand the basic concepts.
- Try to anticipate and visualize the concepts and flight maneuvers.
- With this basic knowledge, your CFI can expand on the specific and finer points, especially when explaining how a task is done in your specific airplane.
- After your flight lesson, task items are fresh in your mind; they will make sense, and you should be able to understand and learn more.
- Study review items so you can explain them to your CFI and your examiner.
- After you study, relax and plan a time to begin preparing for the next flight lesson.

For all Flight Lessons, pages 35-57, remove text cross-references from “Review items” and “Stage check tasks.” Cross-references for “New items” have been changed from page ranges to study units as indicated below and on the following pages.

#### Page 35, Flight Lesson 1: Introduction to Flight, Content, item 2.:

##### 2. New items

- |   |  |
|---|--|
| <input type="checkbox"/> <input type="checkbox"/> <input type="checkbox"/> Certificates and documents - FM 50-53 I                                | <input type="checkbox"/> <input type="checkbox"/> <input type="checkbox"/> Normal and crosswind takeoff and climb - FM 138-144 IV; POH 4                 |
| <input type="checkbox"/> <input type="checkbox"/> <input type="checkbox"/> Airplane logbooks - CFI  | <input type="checkbox"/> <input type="checkbox"/> <input type="checkbox"/> Effect and use of primary flight controls and trim - FM 100-104 I; PH 36-39 1 |
| <input type="checkbox"/> <input type="checkbox"/> <input type="checkbox"/> Airworthiness requirements - FM 54-57 I                                | <input type="checkbox"/> <input type="checkbox"/> <input type="checkbox"/> Practice area familiarization - CFI   |
| <input type="checkbox"/> <input type="checkbox"/> <input type="checkbox"/> Use of checklists - FM 16 I; POH 4                                     | <input type="checkbox"/> <input type="checkbox"/> <input type="checkbox"/> Collision avoidance procedures - PH 176-178 3                                 |
| <input type="checkbox"/> <input type="checkbox"/> <input type="checkbox"/> Preflight inspection - FM 106-110 II; POH 4                            | <input type="checkbox"/> <input type="checkbox"/> <input type="checkbox"/> Normal and crosswind approach - FM 145-164 IV; POH 4                          |
| <input type="checkbox"/> <input type="checkbox"/> <input type="checkbox"/> Airplane servicing - CFI   | <input type="checkbox"/> <input type="checkbox"/> <input type="checkbox"/> After-landing procedures - FM 262-265 X; POH 4                                |
| <input type="checkbox"/> <input type="checkbox"/> <input type="checkbox"/> Location of emergency equipment and survival gear - FM 258-260 IX; CFI | <input type="checkbox"/> <input type="checkbox"/> <input type="checkbox"/> Parking and securing the airplane - FM 262-265 X; POH 4                       |
| <input type="checkbox"/> <input type="checkbox"/> <input type="checkbox"/> Operation of systems - FM 74-78 I; POH 7; CFI                          | <input type="checkbox"/> <input type="checkbox"/> <input type="checkbox"/> Additional items at CFI's discretion _____                                    |
| <input type="checkbox"/> <input type="checkbox"/> <input type="checkbox"/> Engine starting - FM 114-116 II; POH 4                                 |  |
| <input type="checkbox"/> <input type="checkbox"/> <input type="checkbox"/> Taxiing - FM 117-122 II; POH 4   |  |
| <input type="checkbox"/> <input type="checkbox"/> <input type="checkbox"/> Before-takeoff check - FM 123-126 II; POH 4                            |  |

#### Page 36, Flight Lesson 2: Four Fundamentals of Flight, Content, item 4.:

##### 4. New items

- |  |   |
|--|---|
| <input type="checkbox"/> <input type="checkbox"/> <input type="checkbox"/> Taxiing in a crosswind - FM 117-122 II                        | <input type="checkbox"/> <input type="checkbox"/> <input type="checkbox"/> Turns to headings - FM 21-23, 89-104 4, I; CFI; POH 4                  |
| <input type="checkbox"/> <input type="checkbox"/> <input type="checkbox"/> Cockpit Flight deck management - FM 111-113 II                | <input type="checkbox"/> <input type="checkbox"/> <input type="checkbox"/> Descents and descending turns - FM 25-26, 89-104, 4, I; CFI; POH 4     |
| <input type="checkbox"/> <input type="checkbox"/> <input type="checkbox"/> Radio communication procedures - FM 128-129 III; PH 181-184 3 | <input type="checkbox"/> <input type="checkbox"/> <input type="checkbox"/> Cruise descent - FM 25-26, 89-104, 4, I; CFI; POH 4                    |
| <input type="checkbox"/> <input type="checkbox"/> <input type="checkbox"/> Airport and runway markings - FM 134-135 III; PH 142-155 3    | <input type="checkbox"/> <input type="checkbox"/> <input type="checkbox"/> Traffic pattern descent - FM 25-26, 89-104, 4, I; CFI; POH 4           |
| <input type="checkbox"/> <input type="checkbox"/> <input type="checkbox"/> Traffic patterns - FM 130-133 III; PH 166-168 3               | <input type="checkbox"/> <input type="checkbox"/> <input type="checkbox"/> Power-off glide - FM 25-26, 89-104, 4, I; CFI; POH 4                   |
| <input type="checkbox"/> <input type="checkbox"/> <input type="checkbox"/> Straight-and-level flight - FM 20-21, 88-103 4, I; CFI; POH 4 | <input type="checkbox"/> <input type="checkbox"/> <input type="checkbox"/> Level-off from climbs and descents - FM 19-26, 89-104 4, I; CFI; POH 4 |
| <input type="checkbox"/> <input type="checkbox"/> <input type="checkbox"/> Climbs and climbing turns - FM 24-25, 88-103 4, I; CFI; POH 4 | <input type="checkbox"/> <input type="checkbox"/> <input type="checkbox"/> Torque effects - FM 19-26, 89-104 4, I; PH 54-58 1                     |
| <input type="checkbox"/> <input type="checkbox"/> <input type="checkbox"/> Cruise climb - FM 24, 89-104 4, I; CFI; POH 4                 | <input type="checkbox"/> <input type="checkbox"/> <input type="checkbox"/> Additional items at CFI's discretion _____                             |
| <input type="checkbox"/> <input type="checkbox"/> <input type="checkbox"/> Best rate of climb - FM 24, 89-104 4, I; CFI; POH 4           |   |
| <input type="checkbox"/> <input type="checkbox"/> <input type="checkbox"/> Best angle of climb - FM 24, 89-104 4, I; CFI; POH 4          |   |

#### Page 37, Flight Lesson 3: Slow Flight and Stalls, Content, item 4.:

##### 4. New items

- |  |
|--|
| <input type="checkbox"/> <input type="checkbox"/> <input type="checkbox"/> Maneuvering during slow flight - FM 230-233 VIII; PH 50-54 1                  |
| <input type="checkbox"/> <input type="checkbox"/> <input type="checkbox"/> Power-off stalls (entered from straight flight) - FM 234-238 VIII; PH 72-76 1 |
| <input type="checkbox"/> <input type="checkbox"/> <input type="checkbox"/> Power-on stalls (entered from straight flight) - FM 239-243 VIII; PH 72-76 1  |
| <input type="checkbox"/> <input type="checkbox"/> <input type="checkbox"/> Spin awareness - FM 244-246 VIII; PH 77-78 1; POH 3                           |
| <input type="checkbox"/> <input type="checkbox"/> <input type="checkbox"/> Additional items at CFI's discretion _____                                    |



## Page 38, Flight Lesson 4: Emergency Operations, Content, item 4.:

## 4. New items

- |  |   |
|--|---|
| <input type="checkbox"/> <input type="checkbox"/> <input type="checkbox"/> Emergency descent - CFI; POH 3                                    | <input type="checkbox"/> <input type="checkbox"/> <input type="checkbox"/> Emergencies during takeoff roll, initial climb, cruise, descent, and in the traffic pattern - FM 247-255 <b>IX</b> ; POH 3 |
| <input type="checkbox"/> <input type="checkbox"/> <input type="checkbox"/> Emergency approach and landing - FM 249-255 <b>IX</b> ; POH 3     | <input type="checkbox"/> <input type="checkbox"/> <input type="checkbox"/> Normal and crosswind landing - FM 145-161 <b>IV</b>  |
| <input type="checkbox"/> <input type="checkbox"/> <input type="checkbox"/> Systems and equipment malfunctions - FM 256-257 <b>IX</b> ; POH 3 | <input type="checkbox"/> <input type="checkbox"/> <input type="checkbox"/> Recovery from bouncing and ballooning during landing - FM 157-158 <b>IV</b>  |
| <input type="checkbox"/> <input type="checkbox"/> <input type="checkbox"/> Emergency equipment and survival gear - FM 258-260 <b>IX</b>      | <input type="checkbox"/> <input type="checkbox"/> <input type="checkbox"/> Additional items at CFI's discretion _____   |
- 
- 

## Page 39, Flight Lesson 5: Steep Turns and Ground Reference Maneuvers, Content, item 4.:

## 4. New items

- Steep turns - FM 192-196 **V**; PH 53-54 **1**
  - Rectangular course - FM 198-204 **VI**
  - S-turns - FM 205-210 **VI**
  - Turns around a point - FM 211-215 **VI**
  - Wake turbulence avoidance - PH 169-176 **1**
  - Attitude instrument flying (IR)
    - Straight-and-level flight (IR) - FM 265-268 **4**
    - Constant airspeed climbs (IR) - FM 268-274 **4**
    - Constant airspeed descents (IR) - FM 271-275 **4**
    - Turns to a heading (IR) - FM 275-278 **4**
  - Additional items at CFI's discretion \_\_\_\_\_
- 
- 

## Page 41, Flight Lesson 7: Go-Around and Forward Slip to a Landing, Content, item 4.:

## 4. New items

- Go-around/rejected landing - FM 187-190 **IV**
  - Forward slip to a landing - FM 182-186 **IV**
  - Dealing with unexpected requests from ATC - CFI
    - Cross airport to opposite downwind - CFI
    - Reverse direction on downwind - CFI
    - Teardrop maneuver back to final approach from the upwind leg due to a runway change - CFI
  - Wind shear avoidance - FM 130-134 **III**
  - Additional items at CFI's discretion \_\_\_\_\_
- 
- 

## Page 44, Flight Lesson 10: First Solo, Content, item 4.:

## 4. New items (solo in traffic pattern)

- Radio communication procedures - FM 128-129 **III**; PH 181-184 **3**
  - Traffic patterns - FM 130-133 **III**; PH 166-168 **3**
  - Normal and crosswind takeoff and climb (3) - FM 138-144 **IV**
  - Normal and crosswind approach and landing to a full stop (3) - FM 145-161 **IV**
  - Postflight procedures - FM 262-265 **X**
  - Additional items at CFI's discretion \_\_\_\_\_
- 
-

## Page 48, Flight Lesson 13: Short-Field and Soft-Field Takeoffs and Landings, Content, item 4.:

## 4. New items

- Short-field takeoff and maximum performance climb - FM 172-176 **IV**
  - Short-field approach and landing - FM 177-184 **IV**
  - Soft-field takeoff and climb - FM 162-166 **IV**
  - Soft-field approach and landing - FM 167-174 **IV**
  - Recovery from unusual flight attitudes (IR) - FM 278-283 **CFI**
  - Radio communications and radar services (IR) - FM 128-129, 227-228 **III, VII**
  - Additional items at CFI's discretion \_\_\_\_\_
- 

## Page 50, Flight Lesson 15: Dual Cross-Country, Content, item 4.:

## 4. New items

- |   |  |
|---|--|
| <input type="checkbox"/> <input type="checkbox"/> <input type="checkbox"/> Aeronautical charts - PH 427-440 <b>9</b>  | <input type="checkbox"/> <input type="checkbox"/> <input type="checkbox"/> Setting power and fuel mixture - POH 4, 5   |
| <input type="checkbox"/> <input type="checkbox"/> <input type="checkbox"/> <i>Airport/Facility Directory</i> Chart Supplement, Notice to Airmen (NOTAM), and other publications - PH 441-449 <b>9</b> | <input type="checkbox"/> <input type="checkbox"/> <input type="checkbox"/> Estimating in-flight visibility - CFI   |
| <input type="checkbox"/> <input type="checkbox"/> <input type="checkbox"/> National Airspace System - FM 69-73 <b>I</b> ; PH 201-212 <b>3</b>   | <input type="checkbox"/> <input type="checkbox"/> <input type="checkbox"/> Operational problems associated with varying terrain features during the flight - CFI |
| <input type="checkbox"/> <input type="checkbox"/> <input type="checkbox"/> Route selection - FM 65-68 <b>I</b> ; PH 515-524 <b>11</b>   | <input type="checkbox"/> <input type="checkbox"/> <input type="checkbox"/> Recognition of critical weather situations - CFI                                      |
| <input type="checkbox"/> <input type="checkbox"/> <input type="checkbox"/> Navigation log - PH 534 <b>11</b>  | <input type="checkbox"/> <input type="checkbox"/> <input type="checkbox"/> Flight by reference to flight instruments - CFI                                       |
| <input type="checkbox"/> <input type="checkbox"/> <input type="checkbox"/> Obtaining weather information - FM 58-64 <b>I</b> ; PH 383-426 <b>8</b>  | <input type="checkbox"/> <input type="checkbox"/> <input type="checkbox"/> Straight and level flight - CFI   |
| <input type="checkbox"/> <input type="checkbox"/> <input type="checkbox"/> Determining performance and limitations - FM 84-88 <b>I</b> ; PH 295-324 <b>5</b> ; POH 2, 5                               | <input type="checkbox"/> <input type="checkbox"/> <input type="checkbox"/> Turns, climbs, and descents - CFI   |
| <input type="checkbox"/> <input type="checkbox"/> <input type="checkbox"/> Weight and balance computations - PH 313-324 <b>5</b> ; POH 6  | <input type="checkbox"/> <input type="checkbox"/> <input type="checkbox"/> Use of radio aids, ATC directives - CFI   |
| <input type="checkbox"/> <input type="checkbox"/> <input type="checkbox"/> Aeromedical factors - FM 79-83 <b>I</b> ; PH 325-358 <b>6</b>  | <input type="checkbox"/> <input type="checkbox"/> <input type="checkbox"/> Computing groundspeed, ETA, and fuel consumption - PH 453-460 <b>9</b>                |
| <input type="checkbox"/> <input type="checkbox"/> <input type="checkbox"/> Filing a VFR flight plan - PH 522-524 <b>II</b> ; CFI  | <input type="checkbox"/> <input type="checkbox"/> <input type="checkbox"/> Obtaining in-flight weather information - PH 400-403 <b>8</b>                         |
| <input type="checkbox"/> <input type="checkbox"/> <input type="checkbox"/> Course interception - FM 248-224 <b>VII</b>  | <input type="checkbox"/> <input type="checkbox"/> <input type="checkbox"/> Unfamiliar airport operations - CFI   |
| <input type="checkbox"/> <input type="checkbox"/> <input type="checkbox"/> Open VFR flight plan - CFI   | <input type="checkbox"/> <input type="checkbox"/> <input type="checkbox"/> Lost procedures - FM 225-228 <b>VII</b> ; PH 527-530 <b>11</b>                        |
| <input type="checkbox"/> <input type="checkbox"/> <input type="checkbox"/> Pilotage & dead reckoning - FM 248-224 <b>VII</b> ; PH 520-524 <b>11</b>   | <input type="checkbox"/> <input type="checkbox"/> <input type="checkbox"/> Diversion to alternate airport - FM 222-224 <b>VII</b> ; PH 525-527 <b>11</b>         |
| <input type="checkbox"/> <input type="checkbox"/> <input type="checkbox"/> VFR radar services, as appropriate - PH 199-204 <b>3</b>   | <input type="checkbox"/> <input type="checkbox"/> <input type="checkbox"/> Closing a VFR flight plan - PH 524 <b>11</b> ; CFI                                    |
|   | <input type="checkbox"/> <input type="checkbox"/> <input type="checkbox"/> Additional items at CFI's discretion _____  |
- 

## Knowledge Tests and Figures

Pages 63-81: The following pages include revised Stage One, Stage Two, Stage Three, and End-of-Course Knowledge Tests. All referenced figures have been included in this PDF, and the referenced page numbers have been changed to match their location in this document. These new tests reflect changes due to the FAA's deletion of some material covered for the knowledge test as well as some reordering of questions.

The figures on pages 73-81 and inside the front and back covers were updated per the FAA. Many of the figure numbers and some of the figure content changed. Figure 52 was removed.

Replacement pages begin on the next page of this Update PDF. The figures for the inside front and back covers are reproduced on pages 28-29 of this Update PDF.

# STAGE ONE KNOWLEDGE TEST

The figures on pages 20 through 29 are from the FAA's *Airman Knowledge Testing Supplement*, which is available from your flight school or instructor.

Instructors, for a copy of the answer key to all *Sport Pilot Syllabus* Stage Tests, please email a request for the SPSYL Stage Test Answer Key to the Gleim Aviation Department at [aviationteam@gleim.com](mailto:aviationteam@gleim.com).

1. (Refer to Figure 49 on page 25.) Select the proper traffic pattern and runway for landing.
  - A — Left-hand traffic and Runway 18.
  - B — Right-hand traffic and Runway 18.
  - C — Left-hand traffic and Runway 22.
  
2. (Refer to Figure 48 on page 26.) What is the difference between area A and area E on the airport depicted?
  - A — "A" may be used for taxi and takeoff; "E" may be used only as an overrun.
  - B — "A" may be used for all operations except heavy aircraft landings; "E" may be used only as an overrun.
  - C — "A" may be used only for taxiing; "E" may be used for all operations except landings.
  
3. The most effective method of scanning for other aircraft for collision avoidance during daylight hours is to use
  - A — regularly spaced concentration on the 3-, 9-, and 12-o'clock positions.
  - B — a series of short, regularly spaced eye movements to search each 10-degree sector.
  - C — peripheral vision by scanning small sectors and utilizing off-center viewing.
  
4. During departure, when visual separation is employed by Air Traffic Control (ATC), traffic is no longer a factor when
  - A — the other aircraft turns away or is on a diverging course.
  - B — visual contact with the other aircraft is lost.
  - C — the other aircraft is passed.
  
5. VFR flight in controlled airspace above 1,200 feet AGL and below 10,000 feet MSL requires a minimum visibility and vertical cloud clearance of
  - A — 3 miles, and 500 feet below or 1,000 feet above the clouds in controlled airspace.
  - B — 5 miles, and 1,000 feet below or 1,000 feet above the clouds at all altitudes.
  - C — 5 miles, and 1,000 feet below or 1,000 feet above the clouds only in Class A airspace.
  
6. Which incident requires an immediate notification to the nearest NTSB field office?
  - A — A forced landing due to engine failure.
  - B — Landing gear damage, due to a hard landing.
  - C — Flight control system malfunction or failure.
  
7. Which is normally prohibited when operating a restricted category civil aircraft?
  - A — Flight under instrument flight rules.
  - B — Flight over a densely populated area.
  - C — Flight within Class D airspace.
  
8. How long does the Airworthiness Certificate of an aircraft remain valid?
  - A — As long as the aircraft has a current Registration Certificate.
  - B — Indefinitely, unless the aircraft suffers major damage.
  - C — As long as the aircraft is maintained and operated as required by Federal Aviation Regulations.
  
9. If an altimeter setting is not available before flight, to which altitude should the pilot adjust the altimeter?
  - A — The elevation of the nearest airport corrected to mean sea level.
  - B — The elevation of the departure area.
  - C — Pressure altitude corrected for nonstandard temperature.
  
10. What is the maximum weight for a light-sport aircraft (LSA) (not intended for water operations)?
  - A — 600 pounds.
  - B — 1320 pounds.
  - C — 1230 pounds.
  
11. When must batteries in an emergency locator transmitter (ELT) be replaced or recharged, if rechargeable?
  - A — After any inadvertent activation of the ELT.
  - B — When the ELT has been in use for more than 1 cumulative hour.
  - C — When the ELT can no longer be heard over the airplane's communication radio receiver.

**12.** What should an owner or operator know about Airworthiness Directives (ADs)?

- A — For informational purposes only.
- B — They are mandatory.
- C — They are voluntary.

**13.** Except when necessary for takeoff or landing, what is the minimum safe altitude for a pilot to operate an aircraft anywhere?

- A — An altitude allowing, if a power unit fails, an emergency landing without undue hazard to persons or property on the surface.
- B — An altitude of 500 feet above the surface and no closer than 500 feet to any person, vessel, vehicle, or structure.
- C — An altitude of 500 feet above the highest obstacle within a horizontal radius of 1,000 feet.

**14.** No person may operate an aircraft in formation flight

- A — over a densely populated area.
- B — in Class D airspace.
- C — except by prior arrangement with the pilot in command of each aircraft.

**15.** How many passengers is a sport pilot allowed to carry on board?

- A — One.
- B — Two.
- C — Three.

**16.** Who is responsible for determining if an aircraft is in condition for safe flight?

- A — A certificated aircraft mechanic.
- B — The pilot in command.
- C — The owner or operator.

**17.** In addition to other preflight actions for a VFR flight away from the vicinity of the departure airport, regulations specifically require the pilot in command to

- A — review traffic control light signal procedures.
- B — check the accuracy of the navigation equipment and the emergency locator transmitter (ELT).
- C — determine runway lengths at airports of intended use and the aircraft's takeoff and landing distance data.

**18.** A pilot convicted of operating a motor vehicle while either intoxicated by, impaired by, or under the influence of alcohol or a drug is required to provide a

- A — written report to the FAA Civil Aerospace Medical Institute (CAMI) within 60 days after the motor vehicle action.
- B — written report to the FAA Security and Hazardous Materials Safety Office (AXE-700) not later than 60 days after the conviction.
- C — notification of the conviction to an FAA Aviation Medical Examiner (AME) not later than 60 days after the conviction.

**19.** Which cruising altitude is appropriate for a VFR flight on a magnetic course of 135°?

- A — Even thousand.
- B — Even thousand plus 500 feet.
- C — Odd thousand plus 500 feet.

**20.** An alternating red and green light signal directed from the control tower to an aircraft in flight is a signal to

- A — hold position.
- B — exercise extreme caution.
- C — not land; the airport is unsafe.

## STAGE TWO KNOWLEDGE TEST

The figures on pages 20 through 29 are from the FAA's *Airman Knowledge Testing Supplement*, which is available from your flight school or instructor.

1. To find the distance flown in a given time, multiply time by
  - A — ground speed.
  - B — indicated airspeed.
  - C — equivalent airspeed.
  
2. (Refer to Figure 12 on page 20.) The wind direction and velocity at KJFK is from
  - A — 180° true at 4 knots.
  - B — 180° magnetic at 4 knots.
  - C — 040° true at 18 knots.
  
3. (Refer to Figure 23 on page 28.) (Refer to Area 3.) What is the floor of the Savannah Class C airspace at the shelf area (outer circle)?
  - A — 1,200 feet AGL.
  - B — 1,300 feet MSL.
  - C — 1,700 feet MSL.
  
4. (Refer to Figure 15 on page 20.) In the TAF from KOKC, the clear sky becomes
  - A — overcast at 2,000 feet during the forecast period between 2200Z and 2400Z.
  - B — overcast at 200 feet with a 40% probability of becoming overcast at 600 feet during the forecast period between 2200Z and 2400Z.
  - C — overcast at 200 feet with the probability of becoming overcast at 400 feet during the forecast period between 2200Z and 2400Z.
  
5. What values are used for Winds Aloft Forecasts?
  - A — Magnetic direction and knots.
  - B — Magnetic direction and miles per hour.
  - C — True direction and knots.
  
6. (Refer to Figure 52 on page 27.) Traffic patterns in effect at Lincoln Municipal are
  - A — to the right on Runway 14 and Runway 32; to the left on Runway 18 and Runway 35.
  - B — to the left on Runway 14 and Runway 32; to the right on Runway 18 and Runway 35.
  - C — to the right on Runways 14 - 32.
  
7. What is it often called when a pilot pushes his or her capabilities and the aircraft's limits by trying to maintain visual contact with the terrain in low visibility and ceiling?
  - A — Scud running.
  - B — Mind set.
  - C — Peer pressure.
  
8. Density altitude, and its effect on landing performance, is defined by
  - A — pressure altitude and ambient temperature.
  - B — headwind and landing weight.
  - C — humidity and braking friction forces.
  
9. Pilots flying over a national wildlife refuge are requested to fly no lower than
  - A — 1,000 feet AGL.
  - B — 2,000 feet AGL.
  - C — 3,000 feet AGL.
  
10. When outbound from an airport with a UNICOM station on the published common traffic advisory frequency (CTAF) and there is no tower or Flight Service Station (FSS), the pilot should contact UNICOM or use self-announce procedures on CTAF before
  - A — engine start.
  - B — taxiing and before taxiing on the runway.
  - C — the preflight inspection.
  
11. The most comprehensive information on a given airport is provided by
  - A — the Chart Supplement.
  - B — Notices to Airmen (NOTAMs).
  - C — world aeronautical charts (WACs).
  
12. What information is contained in a CONVECTIVE SIGMET?
  - A — Tornadoes, embedded thunderstorms, and hail 3/4 inch or greater in diameter.
  - B — Severe icing, severe turbulence, or widespread dust storms lowering visibility to less than 3 miles.
  - C — Surface winds greater than 40 knots or thunderstorms equal to or greater than video integrator processor (VIP) level 4.

**13.** A state of temporary confusion resulting from misleading information being sent to the brain by various sensory organs is defined as

- A — spatial disorientation.
- B — hyperventilation.
- C — hypoxia.

**14.** One of the purposes for issuing a Temporary Flight Restriction (TFR) is to

- A — announce parachute jump areas.
- B — protect public figures.
- C — identify airport advisory areas.

**15.** What conditions are necessary for the formation of thunderstorms?

- A — High humidity, lifting force, and unstable conditions.
- B — High humidity, high temperature, and cumulus clouds.
- C — Lifting force, moist air, and extensive cloud cover.

**16.** One weather phenomenon which will always occur when flying across a front is a change in the

- A — wind direction.
- B — type of precipitation.
- C — stability of the air mass.

**17.** Steady precipitation preceding a front is an indication of

- A — stratiform clouds with moderate turbulence.
- B — cumuliform clouds with little or no turbulence.
- C — stratiform clouds with little or no turbulence.

**18.** What should pilots state initially when telephoning a weather briefing facility for preflight weather information?

- A — Tell the number of occupants on board.
- B — State their total flight time.
- C — Identify themselves as pilots.

**19.** Which type weather briefing should a pilot request, when departing within the hour, if no preliminary weather information has been received?

- A — Outlook briefing.
- B — Abbreviated briefing.
- C — Standard briefing.

**20.** When may hazardous wind shear be expected?

- A — When stable air crosses a mountain barrier where it tends to flow in layers forming lenticular clouds.
- B — In areas of low-level temperature inversion, frontal zones, and clear air turbulence.
- C — Following frontal passage when stratocumulus clouds form indicating mechanical mixing.

# STAGE THREE KNOWLEDGE TEST

The figures on pages 20 through 29 are from the FAA's *Airman Knowledge Testing Supplement*, which is available from your flight school or instructor.

1. (Refer to Figure 8 on page 21.) What is the effect of a temperature increase from 25 to 50°F on the density altitude if the pressure altitude remains at 5,000 feet?

- A — 1,200-foot increase.
- B — 1,400-foot increase.
- C — 1,650-foot increase.

2. (Refer to Figure 38 on page 24.) Determine the approximate landing ground roll distance.

Pressure altitude	Sea level
Headwind	4 kts
Temperature	Std

- A — 356 feet.
- B — 401 feet.
- C — 490 feet.

3. Maximum endurance is obtained at the point of minimum power to maintain the aircraft

- A — in steady, level flight.
- B — in a long range descent.
- C — at its slowest possible indicated airspeed.

4. (Refer to Figure 34 on page 23.) Calculate the moment of the airplane and determine which category is applicable.

	WEIGHT (LB)	MOM/1000
Empty weight	1,350	51.5
Pilot and front passenger	310	---
Rear passengers	96	---
Fuel, 38 gal.	---	---
Oil, 8 qt.	---	-0.2

- A — 79.2, utility category.
- B — 80.8, utility category.
- C — 81.2, normal category.

5. (Refer to Figure 32 on page 22 and Figure 33 on page 22.) Which action can adjust the airplane's weight to maximum gross weight and the CG within limits for takeoff?

Front seat occupants	425 lb
Rear seat occupants	300 lb
Fuel, main tanks	44 gal

- A — Drain 12 gallons of fuel.
- B — Drain 9 gallons of fuel.
- C — Transfer 12 gallons of fuel from the main tanks to the auxiliary tanks.

6. (Refer to Figure 32 on page 22 and Figure 33 on page 22.) What effect does a 35-gallon fuel burn (main tanks) have on the weight and balance if the airplane weighed 2,890 pounds and the MOM/100 was 2,452 at takeoff?

- A — Weight is reduced by 210 pounds and the CG is aft of limits.
- B — Weight is reduced by 210 pounds and the CG is unaffected.
- C — Weight is reduced to 2,680 pounds and the CG moves forward.

7. What is density altitude?

- A — The height above the standard datum plane.
- B — The pressure altitude corrected for nonstandard temperature.
- C — The altitude read directly from the altimeter.

8. Trim systems are designed to do what?

- A — They relieve the pilot of the need to maintain constant pressure on the flight controls.
- B — They are used during approach and landing to increase wing lift.
- C — They move in the opposite direction from one another to control roll.

9. What effect does an uphill runway slope have upon takeoff performance?

- A — Decreases takeoff speed.
- B — Increases takeoff distance.
- C — Decreases takeoff distance.

10. Which would most likely cause the cylinder head temperature and engine oil temperature gauges to exceed their normal operating ranges?

- A — Using fuel that has a lower-than-specified fuel rating.
- B — Using fuel that has a higher-than-specified fuel rating.
- C — Operating with higher-than-normal oil pressure.

11. (Refer to Figure 4 on page 20.) Which color identifies the never-exceed speed?

- A — Lower limit of the yellow arc.
- B — Upper limit of the white arc.
- C — The red radial line.

12. Applying carburetor heat will

- A — result in more air going through the carburetor.
- B — enrich the fuel/air mixture.
- C — not affect the fuel/air mixture.

13. A positive indication on an ammeter

- A — indicates the aircraft's battery will soon lose its charge.
- B — shows the rate of charge on the battery.
- C — means more current is being drawn from the battery than is being replaced.

14. During flight, when are the indications of a magnetic compass accurate?

- A — Only in straight-and-level unaccelerated flight.
- B — As long as the airspeed is constant.
- C — During turns if the bank does not exceed 18°.

15. Induced drag is a byproduct of lift and will

- A — decrease in direct proportion to increases in angle of attack.
- B — increase in direct proportion to decreases in angle of attack.
- C — increase in direct proportion to increases in angle of attack.

16. An airplane has been loaded in such a manner that the CG is located aft of the aft CG limit. One undesirable flight characteristic a pilot might experience with this airplane would be

- A — a longer takeoff run.
- B — difficulty in recovering from a stalled condition.
- C — stalling at higher-than-normal airspeed.

17. What action can a pilot take to aid in cooling an engine that is overheating during a climb?

- A — Reduce rate of climb and increase airspeed.
- B — Reduce climb speed and increase RPM.
- C — Increase climb speed and increase RPM.

18. One of the main functions of flaps during approach and landing is to

- A — decrease the angle of descent without increasing the airspeed.
- B — permit a touchdown at a higher indicated airspeed.
- C — increase the angle of descent without increasing the airspeed.

19. The critical angle of attack at which an airfoil stalls will

- A — increase if the CG is moved forward.
- B — remain the same regardless of gross weight.
- C — change with an increase in gross weight.

20. Which aileron positions should a pilot generally use when taxiing in strong quartering headwinds?

- A — Aileron up on the side from which the wind is blowing.
- B — Aileron down on the side from which the wind is blowing.
- C — Ailerons neutral.



# END-OF-COURSE KNOWLEDGE TEST

The figures on pages 20 through 29 are from the FAA's *Airman Knowledge Testing Supplement*, which is available from your flight school or instructor.

1. (Refer to Figure 40 on page 25.) Determine the total distance required for takeoff to clear a 50-foot obstacle.

OAT	Std
Pressure altitude	4,000 ft
Takeoff weight	2,800 lb
Headwind component	Calm

- A — 1,500 feet.
- B — 1,750 feet.
- C — 2,000 feet.

2. (Refer to Figure 36 on page 24.) With a reported wind of south at 20 knots, which runway (10, 14, or 24) is appropriate for an airplane with a 13-knot maximum crosswind component?

- A — Runway 10.
- B — Runway 14.
- C — Runway 24.

3. If an aircraft is loaded 90 pounds over maximum certificated gross weight and fuel (gasoline) is drained to bring the aircraft weight within limits, how much fuel should be drained?

- A — 10 gallons.
- B — 12 gallons.
- C — 15 gallons.

4. (Refer to Figure 32 on page 22 and Figure 33 on page 22.) Which action can adjust the airplane's weight to maximum gross weight and the CG within limits for takeoff?

Front seat occupants	425 lb
Rear seat occupants	300 lb
Fuel, main tanks	44 gal

- A — Drain 12 gallons of fuel.
- B — Drain 9 gallons of fuel.
- C — Transfer 12 gallons of fuel from the main tanks to the auxiliary tanks.

5. What is true altitude?

- A — The vertical distance of the aircraft above sea level.
- B — The vertical distance of the aircraft above the surface.
- C — The height above the standard datum plane.

6. (Refer to Figure 12 on page 20.) Which of the reporting stations have VFR weather?

- A — All.
- B — KINK, KBOI, and KJFK.
- C — KINK, KBOI, and KLAX.

7. (Refer to Figure 25 on page 29.) (Refer to Area 3.) The floor of Class B airspace at Dallas Executive Airport is

- A — at the surface.
- B — 3,000 feet MSL.
- C — 3,100 feet MSL.

8. (Refer to Figure 25 on page 29.) (Refer to Area 4.) The airspace directly overlying Fort Worth Meacham is

- A — Class B airspace to 10,000 feet MSL.
- B — Class C airspace to 5,000 feet MSL.
- C — Class D airspace to 3,200 feet MSL.

9. (Refer to Figure 15 on page 20.) The only cloud type forecast in TAF reports is

- A — Nimbostratus.
- B — Cumulonimbus.
- C — Scattered cumulus.

10. Detonation occurs in a reciprocating aircraft engine when

- A — the spark plugs are fouled or shorted out or the wiring is defective.
- B — hot spots in the combustion chamber ignite the fuel/air mixture in advance of normal ignition.
- C — the unburned charge in the cylinders explodes instead of burning normally.

11. If a flight is to be made on a course to the east, with a wind blowing from northeast, the aircraft must be headed

- A — somewhat to the north of east to counteract drift.
- B — south of east to counteract drift.
- C — north to counteract torque.

12. (Refer to Figure 47 on page 25.) Illustration A indicates that the aircraft is

- A — below the glide slope.
- B — on the glide slope.
- C — above the glide slope.

- 13.** Each pilot of an aircraft approaching to land on a runway served by a visual approach slope indicator (VASI) shall
- A — maintain a 3° glide to the runway.
  - B — maintain an altitude at or above the glide slope.
  - C — stay high until the runway can be reached in a power-off landing.
- 14.** A non-tower satellite airport, within the same Class D airspace as that designated for the primary airport, requires radio communications to be established and maintained with the
- A — satellite airport's UNICOM.
  - B — associated Flight Service Station.
  - C — primary airport's control tower.
- 15.** Which condition would cause the altimeter to indicate a lower altitude than true altitude?
- A — Air temperature lower than standard.
  - B — Atmospheric pressure lower than standard.
  - C — Air temperature warmer than standard.
- 16.** The correct method of stating 4,500 feet MSL to ATC is
- A — "FOUR THOUSAND FIVE HUNDRED."
  - B — "FOUR POINT FIVE."
  - C — "FORTY-FIVE HUNDRED FEET MSL."
- 17.** Which condition is most favorable to the development of carburetor icing?
- A — Any temperature below freezing and a relative humidity of less than 50 percent.
  - B — Temperature between 32°F and 50°F and low humidity.
  - C — Temperature between 20°F and 70°F and high humidity.
- 18.** Prior to starting each maneuver, pilots should
- A — check altitude, airspeed, and heading indications.
  - B — visually scan the entire area for collision avoidance.
  - C — announce their intentions on the nearest CTAF.
- 19.** If the outside air temperature (OAT) at a given altitude is warmer than standard, the density altitude is
- A — equal to pressure altitude.
  - B — lower than pressure altitude.
  - C — higher than pressure altitude.
- 20.** In the Northern Hemisphere, the magnetic compass will normally indicate a turn toward the south when
- A — a left turn is entered from an east heading.
  - B — a right turn is entered from a west heading.
  - C — the aircraft is decelerated while on a west heading.
- 21.** When are the four forces that act on an airplane in equilibrium?
- A — During unaccelerated flight.
  - B — When the aircraft is accelerating.
  - C — When the aircraft is at rest on the ground.
- 22.** The presence of ice pellets at the surface is evidence that there
- A — are thunderstorms in the area.
  - B — has been cold frontal passage.
  - C — is a temperature inversion with freezing rain at a higher altitude.
- 23.** Which statement best defines hypoxia?
- A — A state of oxygen deficiency in the body.
  - B — An abnormal increase in the volume of air breathed.
  - C — A condition of gas bubble formation around the joints or muscles.
- 24.** What action can a pilot take to aid in cooling an engine that is overheating during a climb?
- A — Reduce rate of climb and increase airspeed.
  - B — Reduce climb speed and increase RPM.
  - C — Increase climb speed and increase RPM.
- 25.** Which incident requires an immediate notification be made to the nearest NTSB field office?
- A — An overdue aircraft that is believed to be involved in an accident.
  - B — An in-flight radio communications failure.
  - C — An in-flight generator or alternator failure.
- 26.** With certain exceptions, when must each occupant of an aircraft wear an approved parachute?
- A — When a door is removed from the aircraft to facilitate parachute jumpers.
  - B — When intentionally pitching the nose of the aircraft up or down 30° or more.
  - C — When intentionally banking in excess of 30°.
- 27.** With respect to the certification of airmen, which are categories of aircraft?
- A — Gyroplane, helicopter, airship, free balloon.
  - B — Airplane, rotorcraft, glider, lighter-than-air.
  - C — Single-engine land and sea, multiengine land and sea.
- 28.** Prior to takeoff, the altimeter should be set to which altitude or altimeter setting?
- A — The current local altimeter setting, if available, or the departure airport elevation.
  - B — The corrected density altitude of the departure airport.
  - C — The corrected pressure altitude for the departure airport.

- 29.** When must the battery in an emergency locator transmitter (ELT) be replaced (or recharged if the battery is rechargeable)?
- A — After one-half the battery's useful life.
  - B — During each annual and 100-hour inspection.
  - C — Every 24 calendar months.
- 30.** An airplane and an airship are converging. If the airship is left of the airplane's position, which aircraft has the right-of-way?
- A — The airship.
  - B — The airplane.
  - C — Each pilot should alter course to the right.
- 31.** For sport pilot operations, a Second-Class Medical Certificate issued to a 42-year-old pilot on July 15, this year, will expire at midnight on
- A — July 15, 2 years later.
  - B — July 31, 1 year later.
  - C — July 31, 2 years later.
- 32.** When must a current pilot certificate be in the pilot's personal possession or readily accessible in the aircraft?
- A — When acting as a crew chief during launch and recovery.
  - B — Only when passengers are carried.
  - C — Anytime when acting as pilot in command or as a required crewmember.
- 33.** The final authority as to the operation of an aircraft is the
- A — Federal Aviation Administration.
  - B — pilot in command.
  - C — aircraft manufacturer.
- 34.** In order to operate a light-sport aircraft at an airport within, or in airspace within, Class B, C, and D airspace, a sport pilot
- A — does not have to meet any additional requirements.
  - B — must receive ground training on operations within Class B, C, and D airspace.
  - C — must receive and log ground and flight training on operations within Class B, C, and D airspace.
- 35.** A person may not act as a crewmember of a civil aircraft if alcoholic beverages have been consumed by that person within the preceding
- A — 8 hours.
  - B — 12 hours.
  - C — 24 hours.
- 36.** During operations within Class E airspace at altitudes of less than 1,200 feet AGL, the minimum horizontal distance from clouds requirement for VFR flight is
- A — 1,000 feet.
  - B — 1,500 feet.
  - C — 2,000 feet.
- 37.** What is one purpose of wing flaps?
- A — To enable the pilot to make steeper approaches to a landing without increasing the airspeed.
  - B — To relieve the pilot of maintaining continuous pressure on the controls.
  - C — To decrease wing area to vary the lift.
- 38.** (Refer to Figure 9 on page 21.) (Refer to area C.) How should the flight controls be held while taxiing a tailwheel airplane with a left quartering tailwind?
- A — Left aileron up, elevator neutral.
  - B — Left aileron down, elevator neutral.
  - C — Left aileron down, elevator down.
- 39.** What feature is associated with a temperature inversion?
- A — A stable layer of air.
  - B — An unstable layer of air.
  - C — Chinook winds on mountain slopes.
- 40.** Thunderstorms reach their greatest intensity during the
- A — mature stage.
  - B — downdraft stage.
  - C — cumulus stage.

## FIGURES FOR KNOWLEDGE TESTS

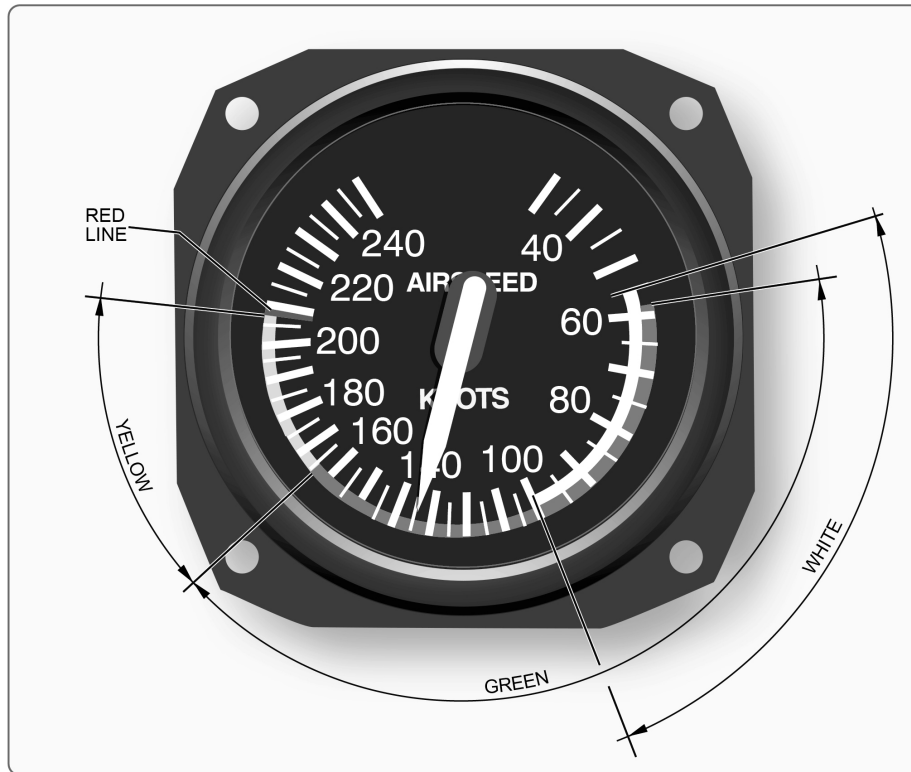

\*NOTE: Figure 4 is in color in the *FAA Airman Knowledge Testing Supplement for Sport Pilot, Recreational Pilot, Remote Pilot, and Private Pilot*, which you will use during your test.

**Figure 4.** Airspeed Indicator.

METAR KINK 121845Z 11012G18KT 15SM SKC 25/17 A3000  
 METAR KBOI 121854Z 13004KT 30SM SCT150 17/6 A3015  
 METAR KLAX 121852Z 25004KT 6SM BR SCT007 SCT007 SCT250 16/15 A2991  
 SPECI KMDW 121856Z 32005KT 1 1/2SM RA OVC007 17/16 A2980 RMK RAB35  
 SPECI KJFK 121853Z 18004KT 1/2SM FG R04/2200 OVC005 20/18 A3006

**Figure 12.** Aviation Routine Weather Reports (METAR).

### TAF

KMEM 121720Z 1218/1324 20012KT 5SM HZ BKN030 PROB40 1220/1222 1SM TSRA OVC008CB  
 FM122200 33015G20KT P6SM BKN015 OVC025 PROB40 1220/1222 3SM SHRA  
 FM120200 35012KT OVC008 PROB40 1202/1205 2SM-RASN BECMG 1306/1308 02008KT BKN012  
 BECMG 1310/1312 00000KT 3SM BR SKC TEMPO 1212/1214 1/2SM FG  
 FM131600 VRB06KT P6SM SKC=  
 KOKC 051130Z 0512/0618 14008KT 5SM BR BKN030 TEMPO 0513/0516 1 1/2SM BR  
 FM051600 18010KT P6SM SKC BECMG 0522/0524 20013G20KT 4SM SHRA OVC020  
 PROB40 0600/0606 2SM TSRA OVC008CB BECMG 0606/0608 21015KT P6SM SCT040=

**Figure 15.** Terminal Aerodrome Forecasts (TAF).

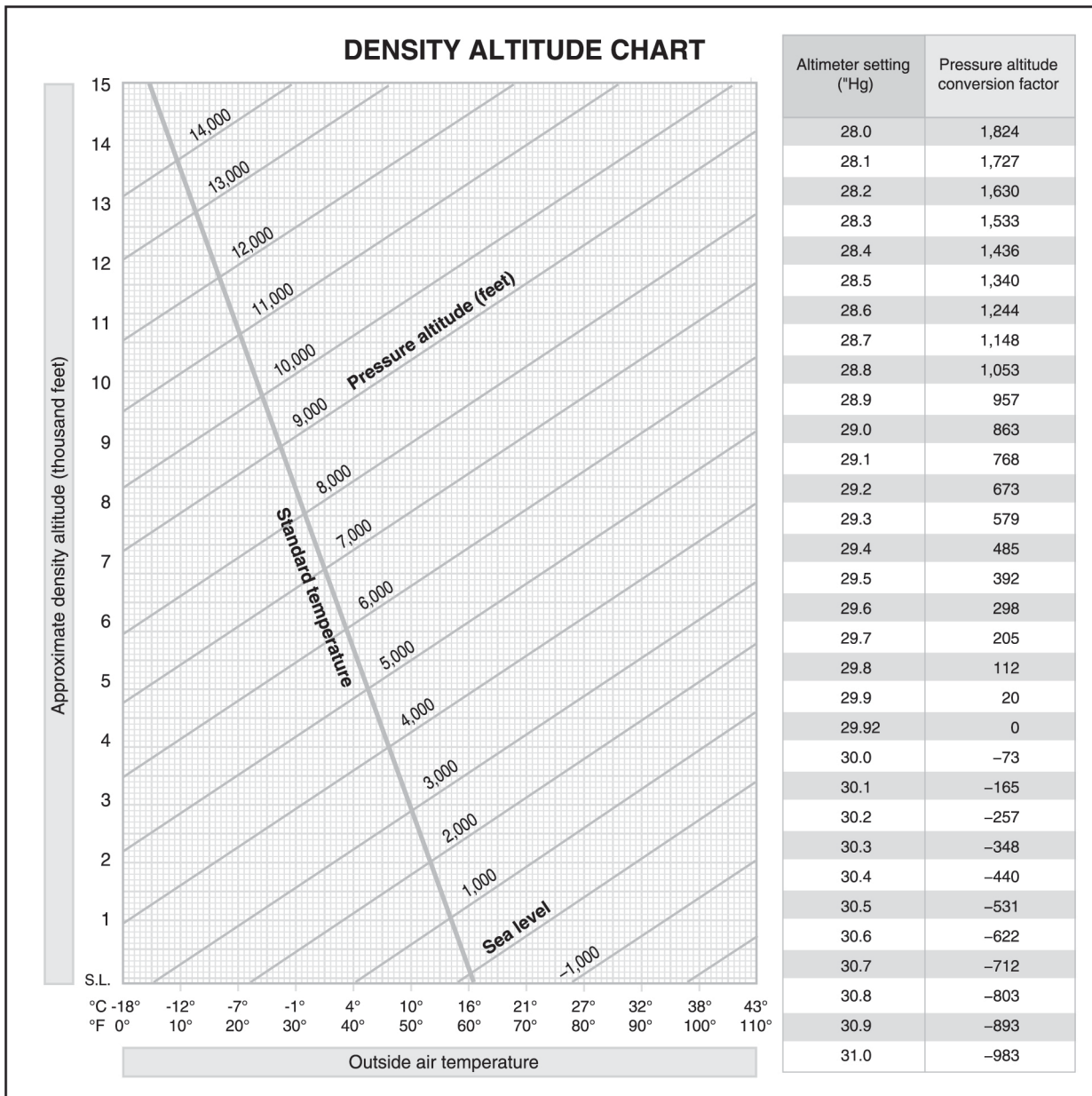

Figure 8. Density Altitude Chart.

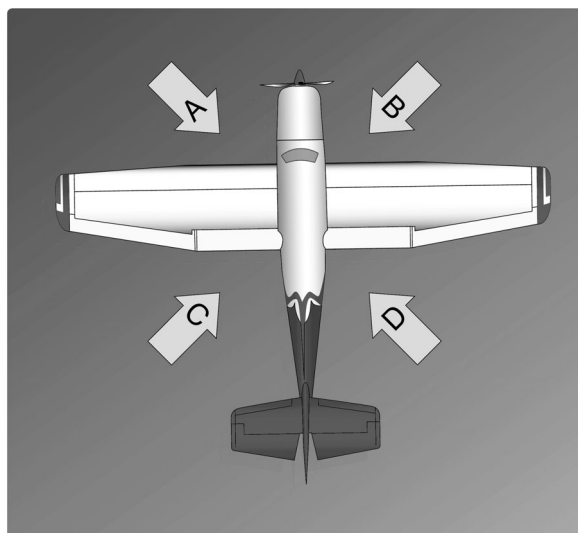

Figure 9. Control Position for Taxi.

Useful load weights and moments			
Baggage or 5th seat occupant		Occupants	
		Front seats ARM 85	Rear seats ARM 121
ARM 140		Weight	Moment 100
Weight	Moment 100	Weight	Moment 100
10	14	120	102
20	28	130	110
30	42	140	119
40	56	150	128
50	70	160	136
60	84	170	144
70	98	180	153
80	112	190	162
90	126	200	170
100	140		
110	154		
120	168		
130	182		
140	196		
150	210		
160	224		
170	238		
180	252		
190	266		
200	280		
210	294		
220	308		
230	322		
240	336		
250	350		
260	364		
270	378		
Usable fuel			
Main wing tanks ARM 75			
Gallons	Weight	Moment 100	
5	30	22	
10	60	45	
15	90	68	
20	120	90	
25	150	112	
30	180	135	
35	210	158	
40	240	180	
44	264	198	
Auxiliary wing tanks ARM 94			
Gallons	Weight	Moment 100	
5	30	28	
10	60	56	
15	90	85	
19	114	107	
*Oil			
Quarts	Weight	Moment 100	
10	19	5	
*Included in basic empty weight.			
Empty weight~2,015 MOM/100~1,554 Moment limits vs weight Moment limits are based on the following weight and center of gravity limit data (landing gear down).			
Weight condition	Forward CG limit	AFT CG limit	
2,950 lb (takeoff or landing)	82.1	84.7	
2,525 lb	77.5	85.7	
2,475 lb or less	77.0	85.7	

Figure 32. Airplane Weight and Balance Tables.

Moment limits vs weight (continued)					
Weight	Minimum Moment 100	Maximum Moment 100	Weight	Minimum Moment 100	Maximum Moment 100
2,100	1,617	1,800	2,500	1,932	2,143
2,110	1,625	1,808	2,510	1,942	2,151
2,120	1,632	1,817	2,520	1,953	2,160
2,130	1,640	1,825	2,530	1,963	2,168
2,140	1,648	1,834	2,540	1,974	2,176
2,150	1,656	1,843	2,550	1,984	2,184
2,160	1,663	1,851	2,560	1,995	2,192
2,170	1,671	1,860	2,570	2,005	2,200
2,180	1,679	1,868	2,580	2,016	2,208
2,190	1,686	1,877	2,590	2,026	2,216
2,200	1,694	1,885	2,600	2,037	2,224
2,210	1,702	1,894	2,610	2,048	2,232
2,220	1,709	1,903	2,620	2,058	2,239
2,230	1,717	1,911	2,630	2,069	2,247
2,240	1,725	1,920	2,640	2,080	2,255
2,250	1,733	1,928	2,650	2,090	2,263
2,260	1,740	1,937	2,660	2,101	2,271
2,270	1,748	1,945	2,670	2,112	2,279
2,280	1,756	1,954	2,680	2,123	2,287
2,290	1,763	1,963	2,690	2,133	2,295
2,300	1,771	1,971	2,700	2,144	2,303
2,310	1,779	1,980	2,710	2,155	2,311
2,320	1,786	1,988	2,720	2,166	2,319
2,330	1,794	1,997	2,730	2,177	2,326
2,340	1,802	2,005	2,740	2,188	2,334
2,350	1,810	2,014	2,750	2,199	2,342
2,360	1,817	2,023	2,760	2,210	2,350
2,370	1,825	2,031	2,770	2,221	2,358
2,380	1,833	2,040	2,780	2,232	2,366
2,390	1,840	2,048	2,790	2,243	2,374
2,400	1,848	2,057	2,800	2,254	2,381
2,410	1,856	2,065	2,810	2,265	2,389
2,420	1,863	2,074	2,820	2,276	2,397
2,430	1,871	2,083	2,830	2,287	2,405
2,440	1,879	2,091	2,840	2,298	2,413
2,450	1,887	2,100	2,850	2,309	2,421
2,460	1,894	2,108	2,860	2,320	2,428
2,470	1,902	2,117	2,870	2,332	2,436
2,480	1,911	2,125	2,880	2,343	2,444
2,490	1,921	2,134	2,890	2,354	2,452
			2,900	2,365	2,460
			2,910	2,377	2,468
			2,920	2,388	2,475
			2,930	2,399	2,483
			2,940	2,411	2,491
			2,950	2,422	2,499

Figure 33. Airplane Weight and Balance Tables.

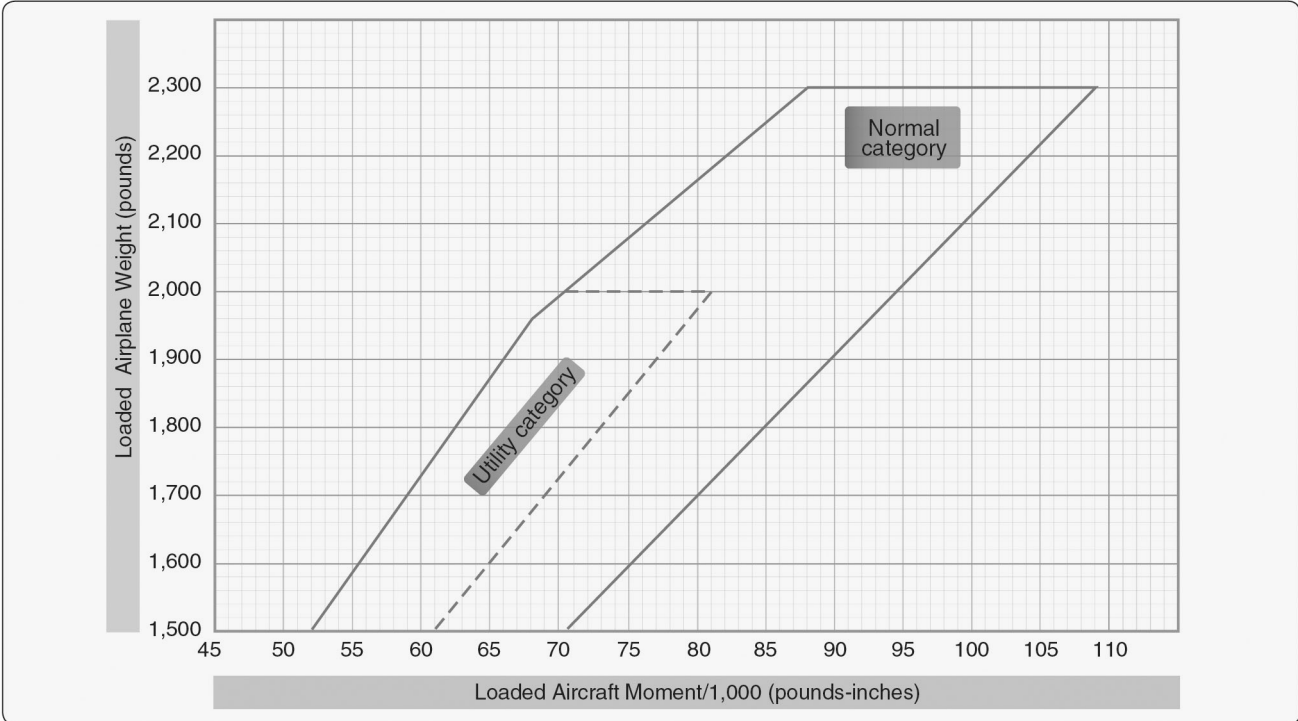
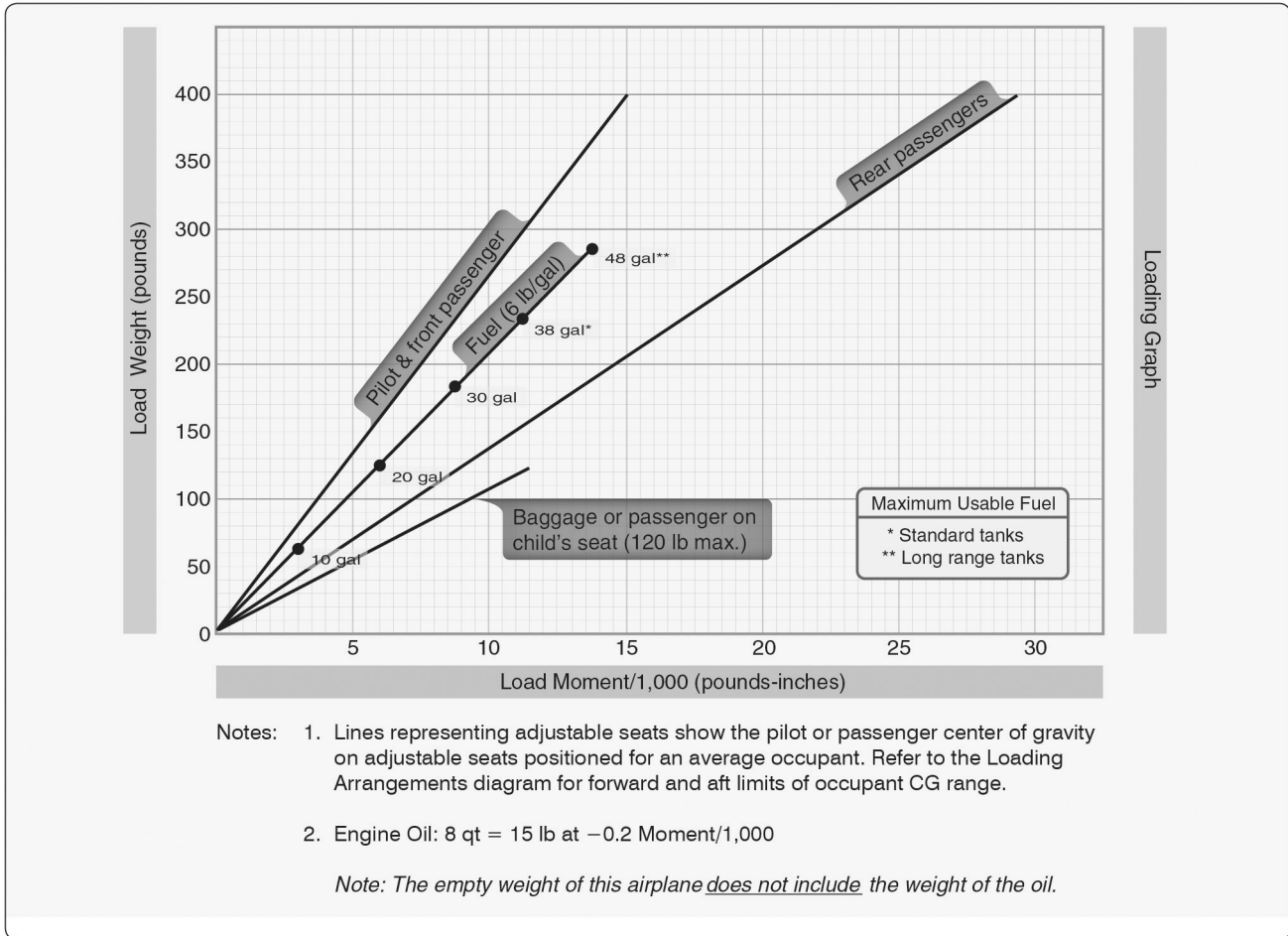

**Figure 34.** Airplane Weight and Balance Graphs.

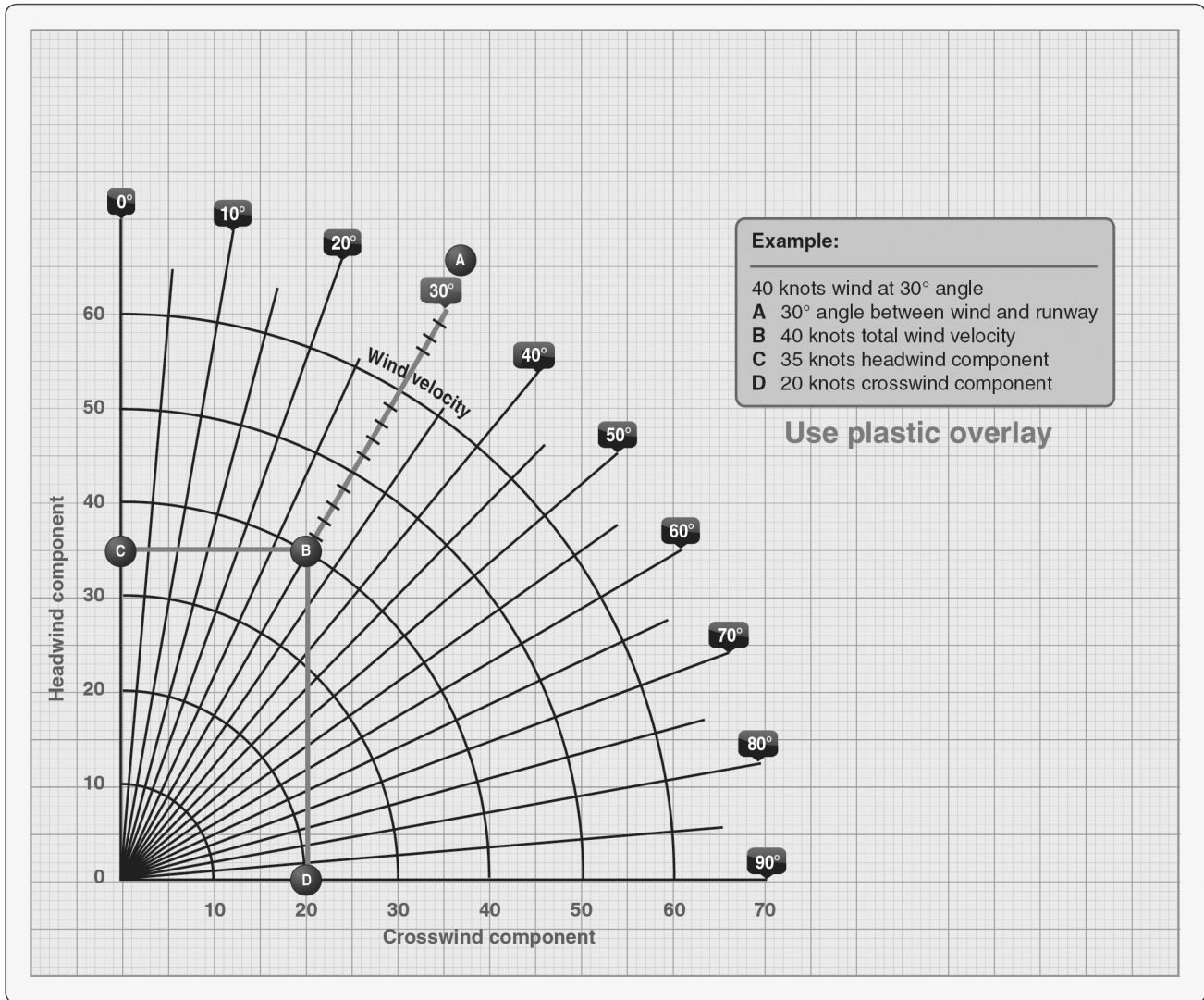

Figure 36. Crosswind Component Graph.

		Landing distance				Flaps lowered to 40° – Power off Hard surface runway – Zero wind			
Gross weight lb	Approach speed, IAS, MPH	At sea level & 59 °F		At 2,500 feet & 50 °F		At 5,000 feet & 41 °F		At 7,500 feet & 32 °F	
		Ground roll	Total to clear 50 feet OBS	Ground roll	Total to clear 50 feet OBS	Ground roll	Total to clear 50 feet OBS	Ground roll	Total to clear 50 feet OBS
1,600	60	445	1,075	470	1,135	495	1,195	520	1,255

**NOTE:**  
 1. Decrease the distances shown by 10% for each 4 knots of headwind.  
 2. Increase the distance by 10% for each 60 °F temperature increase above standard.  
 3. For operation on a dry, grass runway, increase distance (both "ground roll" and "total to clear 50 feet obstacle") by 20% of the "total to clear 50 feet obstacle" figure.

Figure 38. Airplane Landing Distance Table.



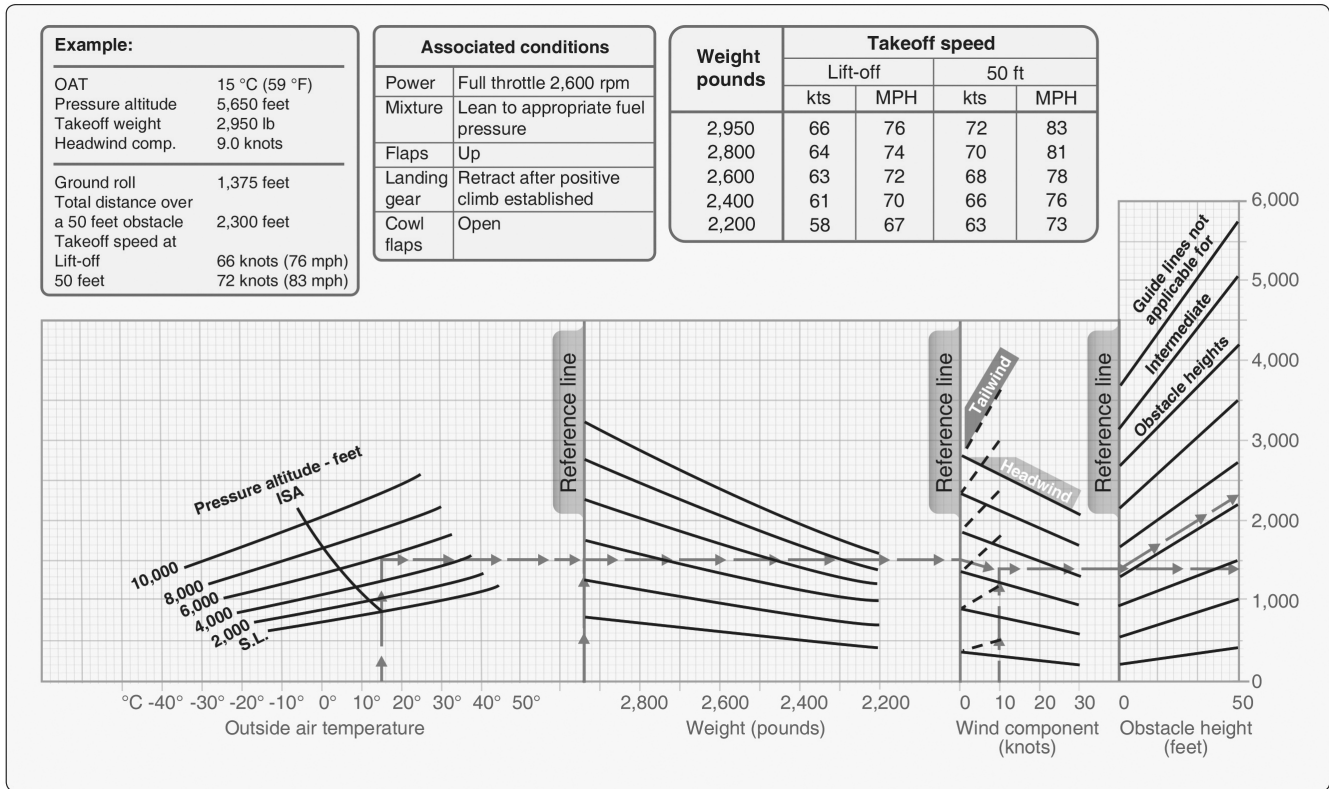

Figure 40. Airplane Takeoff Distance Graph.

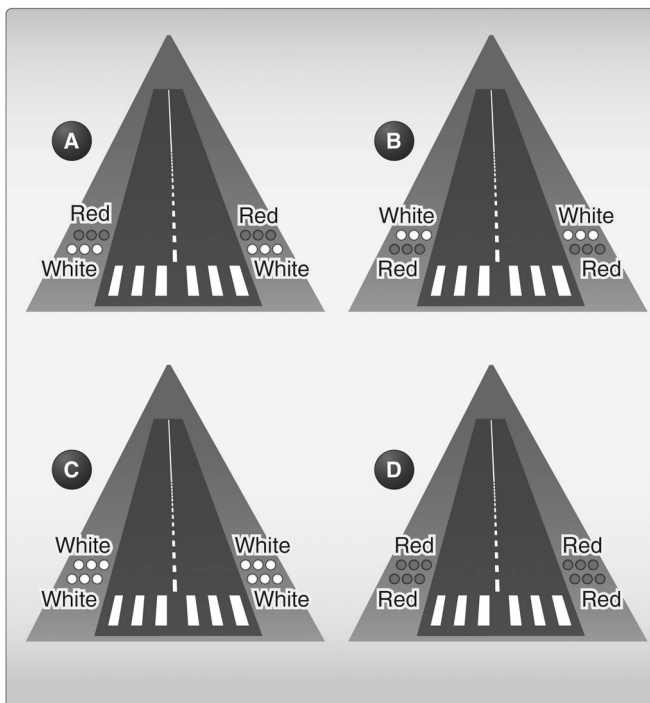

Figure 47. VASI Illustrations.

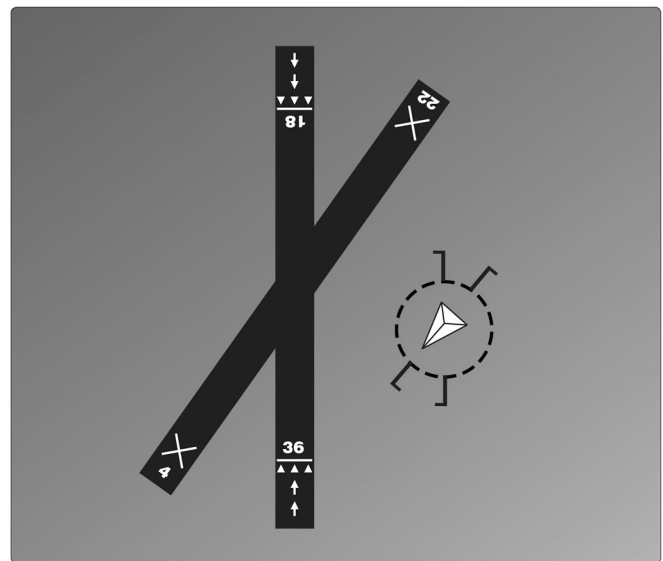

Figure 49. Airport Diagram.

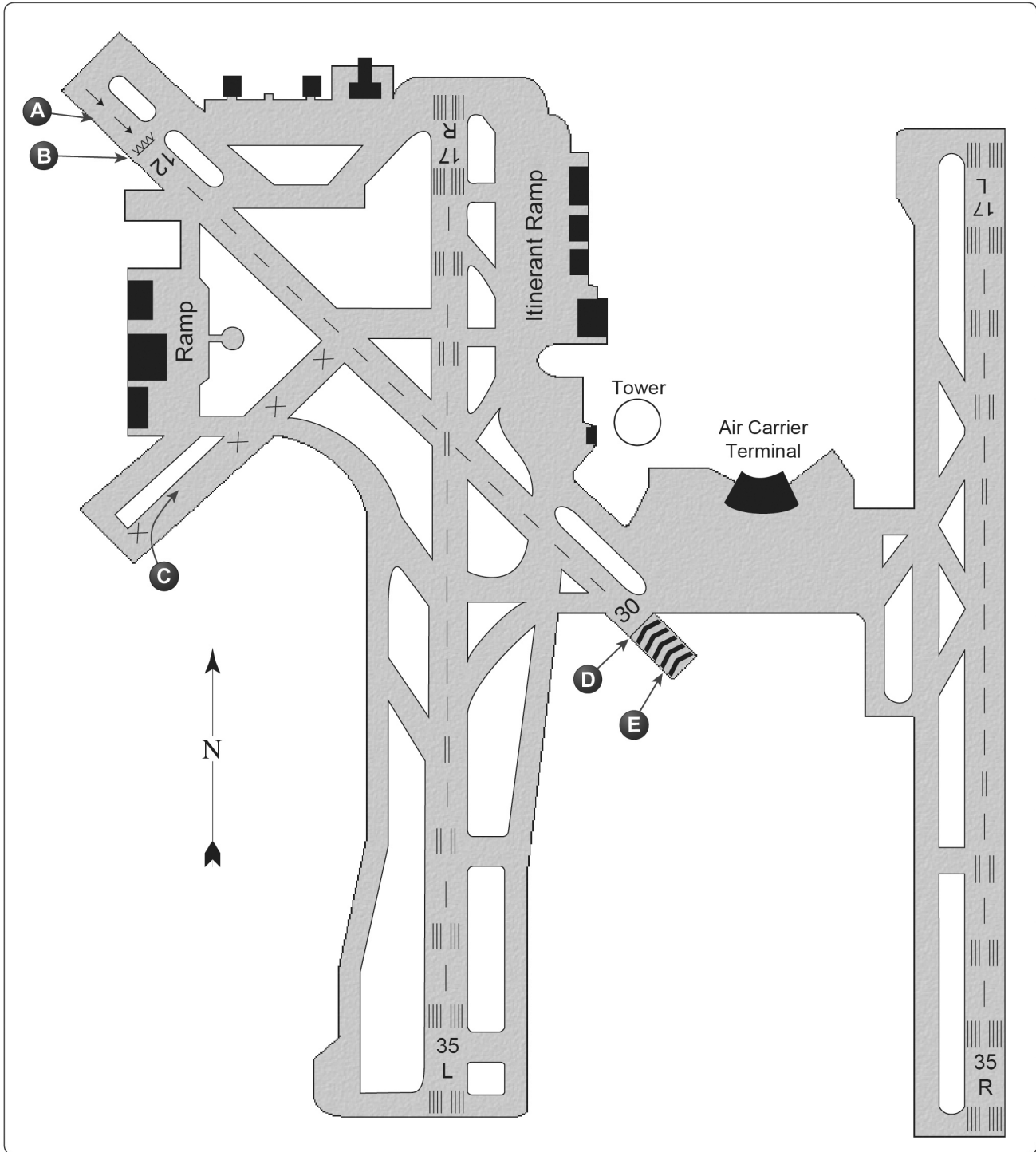

Figure 48. Airport Diagram.

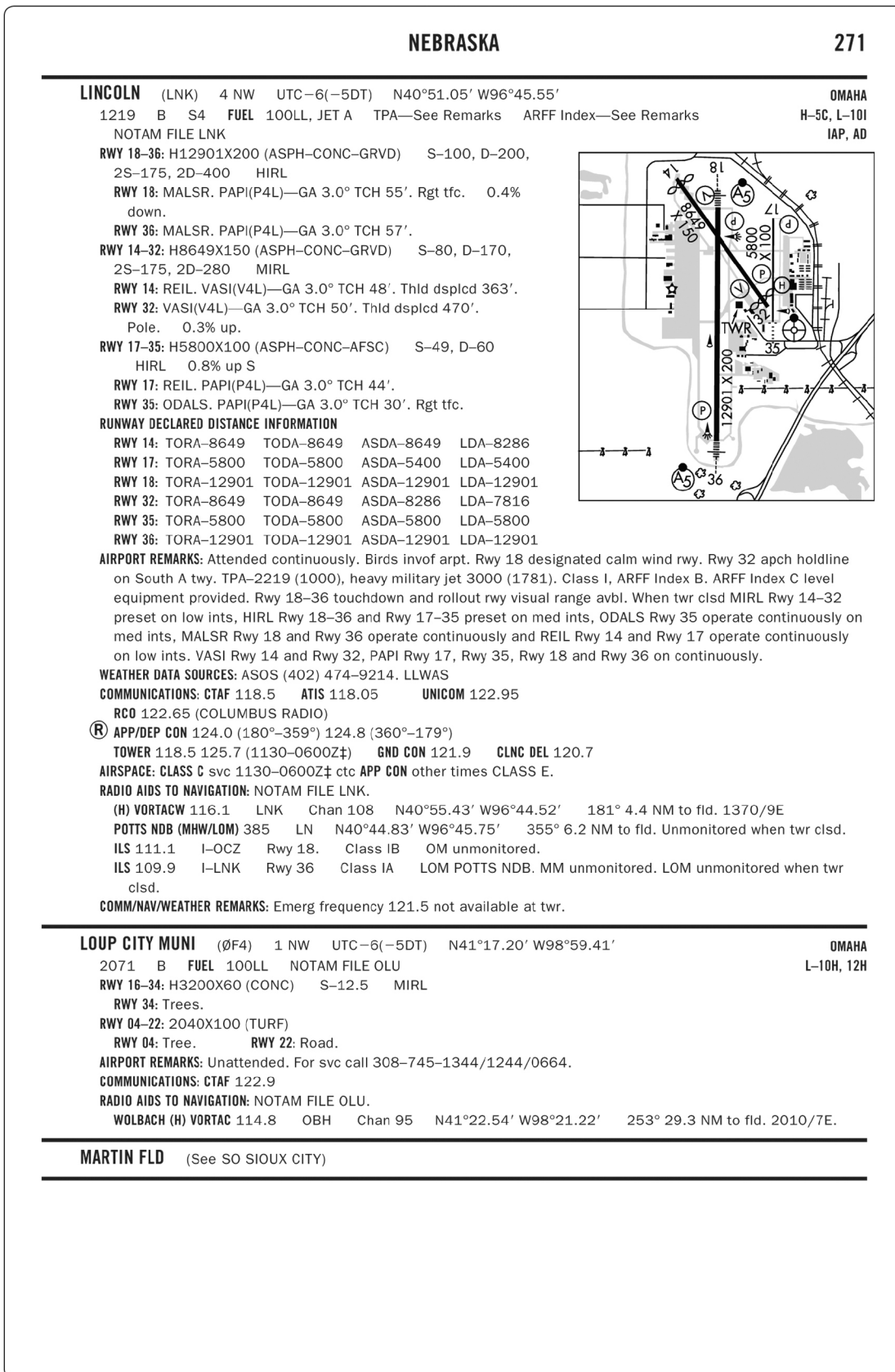

Figure 52. Chart Supplement.

# Inside front cover

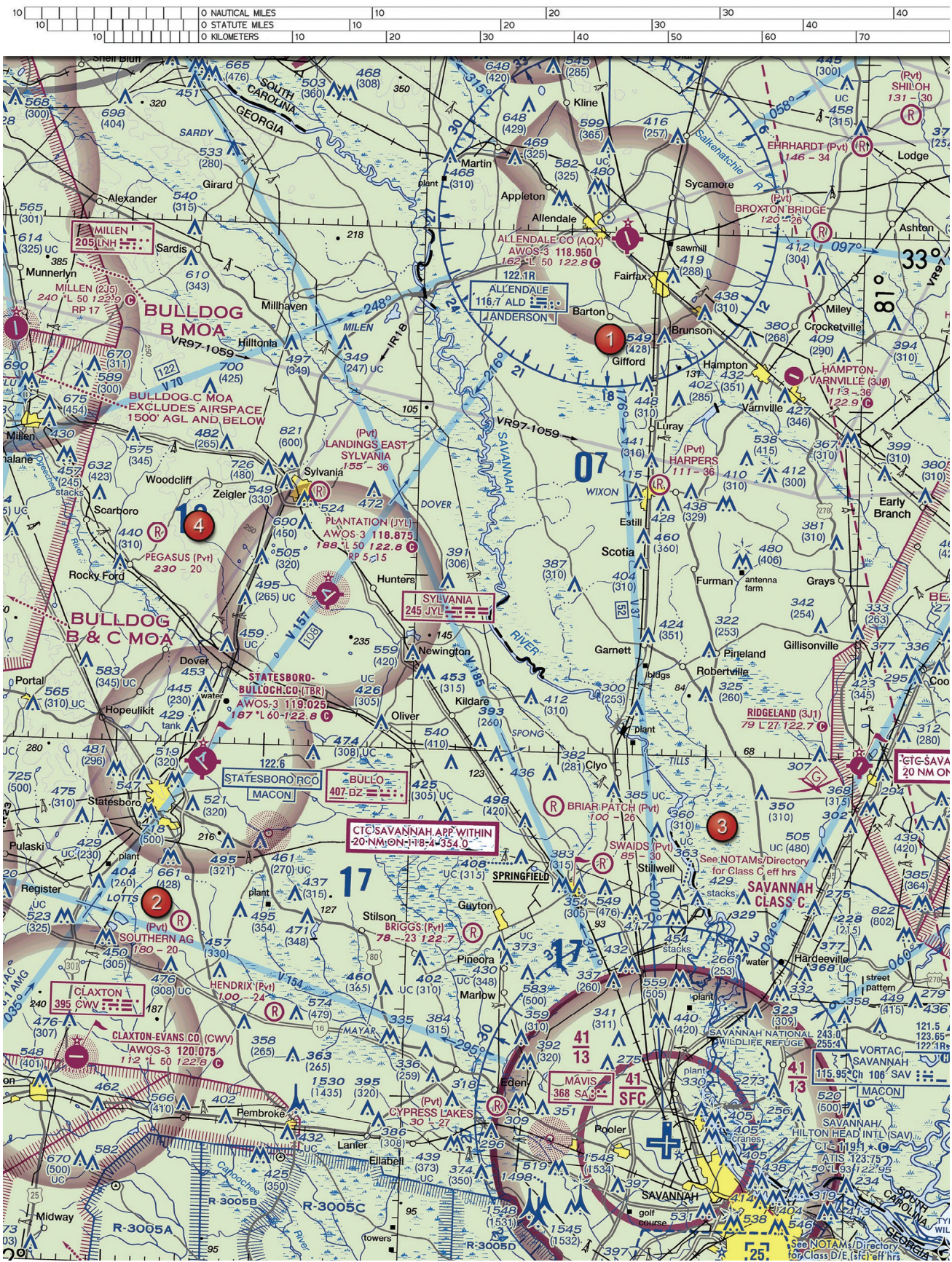

Figure 23. Sectional Chart Excerpt.

NOTE: Chart is not to scale and should not be used for navigation. Use associated scale.

Inside Back Cover

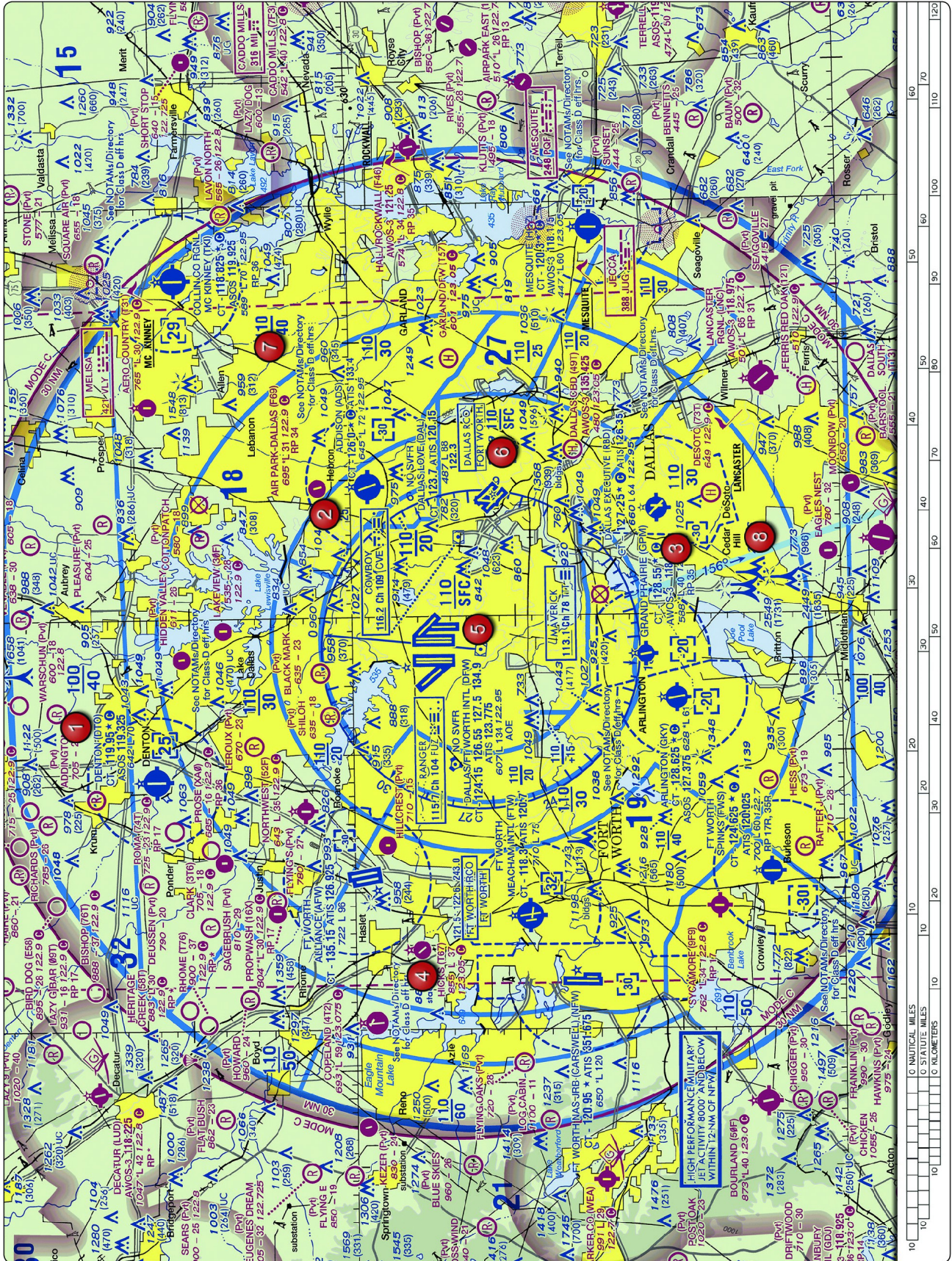

Figure 25. Sectional Chart Excerpt.

NOTE: Chart is not to scale and should not be used for navigation. Use associated scale.